



SAF ● HERCULES

FOR CURTAINSIDERS, REFRIGERATED
VEHICLES, TANKERS AND SILO
TRAILERS, TIPPERS AND WALKING
FLOOR TRAILERS, LOW-LOADER AND
HEAVY DUTY TRANSPORTER

SAF HERCULES

Exceptionally robust
and economical

Tried, tested and appreciated worldwide

High quality, cost-effectiveness and reliability combined with a very long service life – the reasons why landing gear from SAF-HOLLAND has an excellent international reputation.

Our landing gear is ideal for very different scenarios, from the icy cold of Scandinavia to the shimmering desert heat of the Middle East. Ease of use and fantastic functional reliability mean that little force is required, taking some of the strain of daily coupling and uncoupling.



SPECIALLY DESIGNED FOR
CURTAINSIDERS, REFRIGERATED
VEHICLES, TANKERS AND SILO
TRAILERS, AS WELL AS TIPPERS
AND WALKING FLOOR
TRAILERS, LOW-LOADER AND
HEAVY DUTY TRANSPORTER

SAF 3D backplate

- Continuous 10-hole 3D backplate guarantees a variety of mounting options and facilitates the replacement of landing gear on the market

SAF gearbox

- External, compact gearbox with low installation depth enables easy inspection when needed
- The impact-resistant gearbox with a special seal is suitable for use in harsh operating conditions
- Switch easily between high and low gear

Additional advantages

- Weight-optimised: Weight reduction per set 8 kg compared to the SAF TITAN Pro
- Special coating provides long-term protection against environmental factors and stone chipping
- Web-based spare part identification via QR code on the support legs

**3-YEAR
GUARANTEE**

SAF HERCULES TECHNICAL DATA

- Lift capacity:** 24,000 kg
- Static load capacity:** 50,000 kg
- Lift in low gear:** 1 mm per turn
- Lift in high gear:** 12 mm per turn

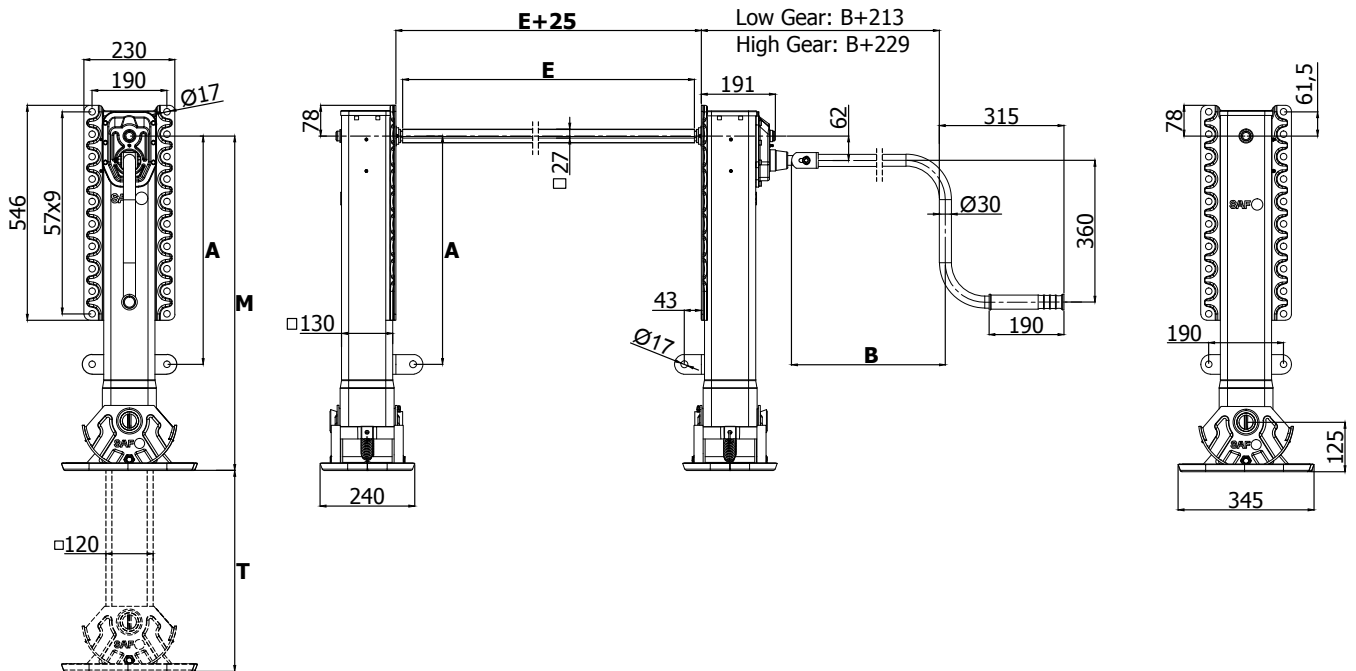

3 YEARS
 MAINTENANCE-FREE
 THANKS TO THE
 SAF SPECIAL GREASE

Landing gear

Height M [mm]	Travel T [mm]	A [mm]			Compensator	Sandshoe high	Sandshoe low
850	510	580	exact Dimensions	M + T [mm]	850 - 510 mm	840 - 510 mm	780 - 510 mm
			with Gearbox	Type	LGH G 85-51 F S	LGH G 85-51 F T	LGH G 85-51 F TC
				Order no.	03 389 0002 00	03 389 0012 00	03 389 0022 00
				Weight [kg]	48,5	47,0	45,5
			without Gearbox	Type	LGH O 85-51 F S	LGH O 85-51 F T	LGH O 85-51 F TC
				Order no.	03 389 0001 00	03 389 0011 00	03 389 0021 00
				Weight [kg]	45,0	43,5	42,0
			Kit**	Type	LGH S 85-51 F S	LGH S 85-51 F T	LGH S 85-51 F TC
				Order no.	03 389 0061 00	03 389 0066 00	03 389 0071 00
800	460	530	exact Dimensions	M + T [mm]	800 - 460 mm	790 - 460 mm	730 - 460 mm
			with Gearbox	Type	LGH G 80-46 F S	LGH G 80-46 F T	LGH G 80-46 F TC
				Order no.	03 389 0004 00	03 389 0014 00	03 389 0024 00
				Weight [kg]	46,9	45,3	43,8
			without Gearbox	Type	LGH O 80-46 F S	LGH O 80-46 F T	LGH O 80-46 F TC
				Order no.	03 389 0003 00	03 389 0013 00	03 389 0023 00
				Weight [kg]	43,3	41,8	40,3
			Kit**	Type	LGH S 80-46 F S	LGH S 80-46 F T	LGH S 80-46 F TC
				Order no.	03 389 0062 00	03 389 0067 00	03 389 0072 00
750	410	-*	exact Dimensions	M + T [mm]	750 - 410 mm	740 - 410 mm	680 - 410 mm
			with Gearbox	Type	LGH G 75-41 F S	LGH G 75-41 F T	LGH G 75-41 F TC
				Order no.	03 389 0006 00	03 389 0016 00	03 389 0026 00
				Weight [kg]	45,3	43,7	42,2
			without Gearbox	Type	LGH O 75-41 F S	LGH O 75-41 F T	LGH O 75-41 F TC
				Order no.	03 389 0005 00	03 389 0015 00	03 389 0025 00
				Weight [kg]	41,7	40,2	38,7
			Kit**	Type	LGH S 75-41 F S	LGH S 75-41 F T	LGH S 75-41 F TC
				Order no.	03 389 0063 00	03 389 0068 00	03 389 0073 00
700	400/360	-*	exact Dimensions	M + T [mm]	705 - 400 mm	690 - 360 mm	630 - 360 mm
			with Gearbox	Type	LGH G 70-40 F S	LGH G 70-36 F T	LGH G 70-36 F TC
				Order no.	03 389 0008 00	03 389 0018 00	03 389 0028 00
				Weight [kg]	44,0	42,0	40,5
			without Gearbox	Type	LGH O 70-40 F S	LGH O 70-36 F T	LGH O 70-36 F TC
				Order no.	03 389 0007 00	03 389 0017 00	03 389 0027 00
				Weight [kg]	40,4	38,5	37,0
			Kit**	Type	LGH S 70-40 F S	LGH S 70-36 F T	LGH S 70-36 F TC
				Order no.	03 389 0064 00	03 389 0069 00	03 389 0074 00
650	350/310	-*	exact Dimensions	M + T [mm]	655 - 350 mm	640 - 310 mm	580 - 310 mm
			with Gearbox	Type	LGH G 65-35 F S	LGH G 65-31 F T	LGH G 65-31 F TC
				Order no.	03 389 0010 00	03 389 0020 00	03 389 0030 00
				Weight [kg]	42,3	40,3	38,8
			without Gearbox	Type	LGH O 65-35 F S	LGH O 65-31 F T	LGH O 65-31 F TC
				Order no.	03 389 0009 00	03 389 0019 00	03 389 0029 00
				Weight [kg]	38,7	36,8	35,3
			Kit**	Type	LGH S 65-35 F S	LGH S 65-31 F T	LGH S 65-31 F TC
				Order no.	03 389 0065 00	03 389 0070 00	03 389 0075 00

*Bracing attachment can be ordered loose

Connecting shaft

Length E [mm]	Order no.	Length E [mm]	Order no.
1110	01 435 0038 00	1600	01 435 0030 00
1164	01 435 0022 00	1605	01 435 0031 00
1340	01 435 0023 00	1635	01 435 0032 00
1425	01 435 0037 00	1700	01 435 0033 00
1440	01 435 0024 00	1790	01 435 0034 00
1450	01 435 0025 00	1800**	01 435 0035 00
1470	01 435 0026 00	1950	01 435 0036 00
1500	01 435 0027 00		
1505	01 435 0028 00		
1535	01 435 0039 00		
1575	01 435 0029 00		

**Standard parts in every kit

Foot-Kits

Type	Order no.
Spare Part Kit „Compensating Foot“	03 370 1000 00
Spare Part Kit „Compensating Foot“ (for overall height 650 + 700 mm)	02 370 1006 00
Spare Part Kit „Sandshoe High“	03 370 1001 00
Spare Part Kit „Sandshoe Low“	03 370 1004 00

Further versions on request

Bracing attachment loose for mounting height 650-700-750

Weight [kg]	Order no.
1.1**	02 045 0056 00

Crank handle

Length B [mm]	Order no.
285	01 209 0001 00
350	01 209 0002 00
450	01 209 0003 00
535**	01 209 0004 00
605	01 209 0005 00

Crank holder

Length [mm]	Order no.
260**	01 189 0135 00



TRAILER AXLES AND
SUSPENSION SYSTEMS



COUPLING AND LIFTING
TECHNOLOGIES



SUSPENSIONS FOR
TRUCKS AND BUSES



SUSPENSIONS AND COMPONENTS
FOR COMMERCIAL VEHICLES



BUS AIR SUSPENSIONS
SYSTEMS



V. ORLANDI

COUPLING AND LIFTING
TECHNOLOGIES



TRAILER AXLES AND
SUSPENSIONS SYSTEMS